

T-57, G2 Light Kit Mounting Instructions

- Step 1. Lower the liftgate to the ground. To avoid a risk of an electrical short, disconnect the power cable from the positive side of the battery or manually trip the circuit breaker.
- Step 2. Remove the mainframe box cover by removing the three 5/16" hex nuts with a 1/2" wrench or socket (Figure 1).
- Step 3. Remove two 1-1/4" and four 1/4" plastic plugs from access holes (Figure 2).
- NOTE:** If the box cover does not have either 1/4" or 1-1/4" holes in it do Step 4.
- Step 4. Drill two 1-1/4" and four 1/4" holes at locations indicated (Figure 3).

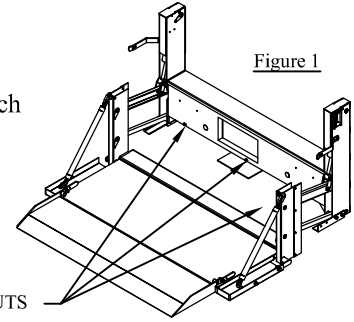

(3) 5/16 HEX NUTS

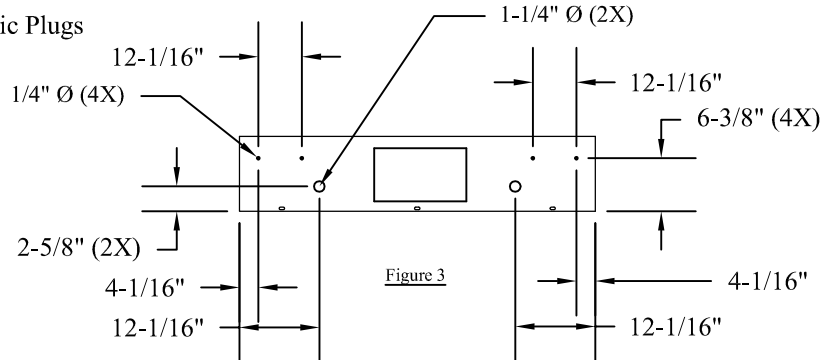
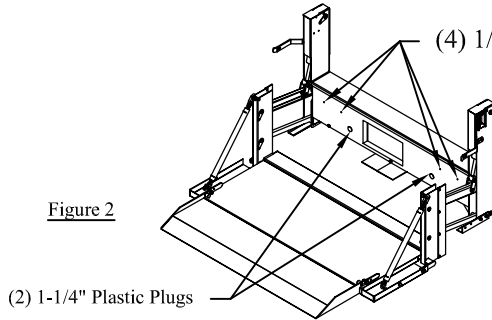

- Step 5. Route the harness through the access holes where plastic plugs were removed in step 3.
- A. Pull two 2-prong light clips and a 3-prong light clip through each 1-1/4" access hole (Figure 2).
- NOTE:** Make sure that the clip with the yellow wire is on the U.S. driver's side and the clip with the green wire is on the U.S. passenger's side.
- B. Locate the two brown wires and the two white wires without any clips on them.
- Connect one brown wire to the red wire on the license plate light using a heat shrink butt connector.
- Connect one white wire to the black wire on the license plate light using a heat shrink butt connector.
- NOTE:** Leave harness draped loosely in mainframe until all components are installed.

- Step 6. Install 1-1/4" rubber grommets in access holes.
- A. Cut the 1-1/4" grommet from the inner hole out (Figure 4).
- B. Place 1-1/4" grommet around wires (Figure 4)
- C. Push 1-1/4" grommets into the access holes.

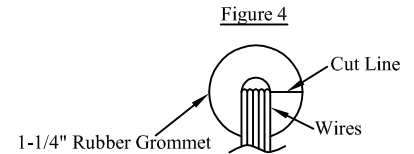

- Step 7. Assemble the light kit as shown using the supplied 1/4-20x3/4" bolts and 1/4-20 Keps nuts. Do not tighten at this time. (Figure 6).

NOTE: Make sure that the warning sticker is facing up before attaching the light kit to liftgate (Figure 5).

Figure 5



NOTE: Before attaching the light kit to lift gate, make sure to route the harness through the back of the light kit. Making sure that no wires are pinched between the kit and the liftgate.

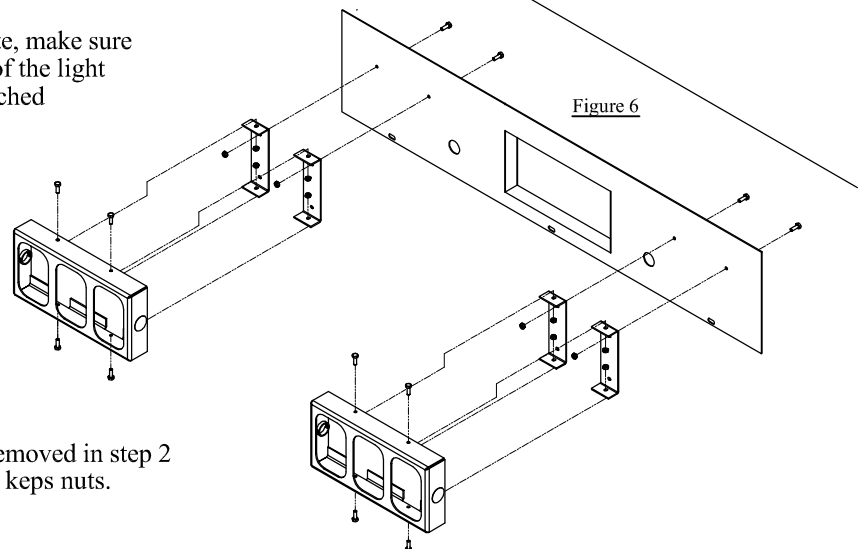

- Step 8. Bolt the light kit to the main frame box cover removed in step 2 using the supplied 1/4-20x3/4" bolts and 1/4-20 keps nuts. Tighten all bolts to 9ft-lb (Figure 6).

T-57, G2 Light Kit Mounting Instructions

Step 9. Press rubber grommets into light holes (Figure 7).

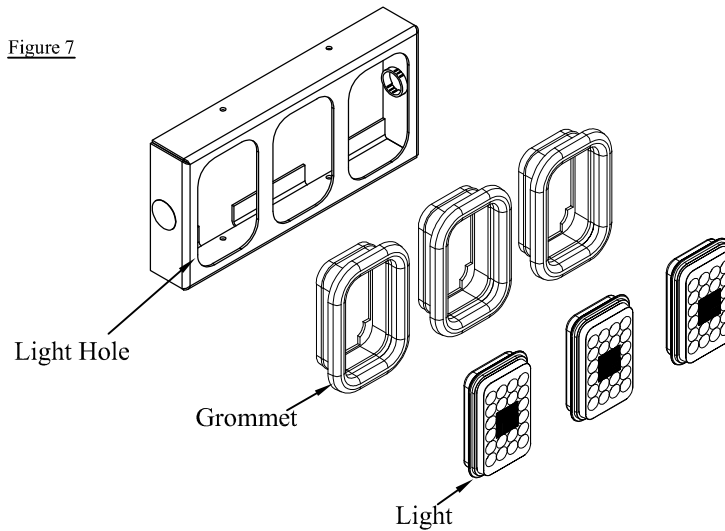

Step 10. Pull harness clips through the inserted grommets. Connect the clips to lights (Figure 8).

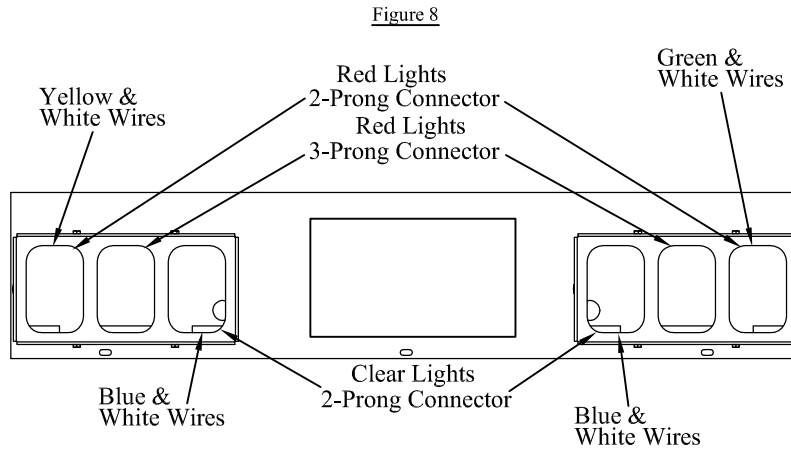

Step 11. Connect the provided wiring harness to the vehicle's existing wiring. Follow the recommended electrical guidelines when connecting the wiring harness to the vehicle.

Step 12. Check for proper operation of lights.

Step 13. If the lights are in correct operation, push lights into installed rubber grommets (Figure 9).

Step 14. Wire tie harness out of the way of moving components.

Step 15. Verify proper operation of lights.

Step 16. Reinstall the box cover on the liftgate and reconnect the liftgate's main power cable.

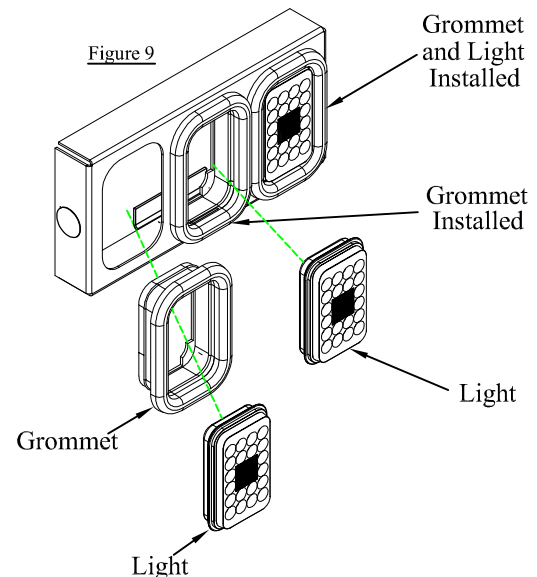

T-57, G2 Light Wiring Diagrams

ELECTRICAL GUIDELINES:

- (1) THE INSTALLER IS RESPONSIBLE FOR USING PROPER TECHNIQUES WHEN INTERFACING WITH VEHICLE ELECTRICAL SYSTEMS.
- (2) FAILURE TO COMPLY WITH THE OEM GUIDELINES COULD RESULT IN UNSAFE VEHICLE OPERATION, FAILURE OF OEM WIRING, OR VEHICLE FIRE.
- (3) NEVER REPLACE OEM FUSES AND/OR CIRCUIT BREAKERS WITH FUSES OR CIRCUIT BREAKERS WITH A HIGHER RATING.
- (4) THE TOTAL CIRCUIT CURRENT DRAW SHOULD NOT EXCEED 80 % OF THE OEM CIRCUIT FUSE OR CIRCUIT BREAKER.
- (5) USE BODY BUILDER JUNCTION BLOCKS, CUSTOMER ACCESS CIRCUITS & CONNECTORS RATHER THAN EXTENDING OEM CIRCUITS.
- (6) INCORPORATE RELAYS INSTEAD OF SPLICING INTO THE OEM ELECTRICAL SYSTEM.
- (7) USE APPROPRIATE GAUGE WIRE FOR EXTENDING CIRCUITS. THE WIRE GAUGE SHOULD BE CAPABLE OF SUPPORTING THE MAXIMUM LOAD TO WHICH THE ADDED CIRCUIT WILL BE EXPOSED.
- (8) OEM ELECTRICAL WIRE COLOR CODING SHOULD BE MAINTAINED WHEN EXTENDING CIRCUITS.
- (9) WHEN ADDING CIRCUITS, ALWAYS INCORPORATE FUSE OR CIRCUIT BREAKER PROTECTION.

• **NOTE:** SYMBOL INDICATED USAGE OF HEAT SHINK BUTT CONNECTOR

COMBINED STOP/TURN FUNCTION

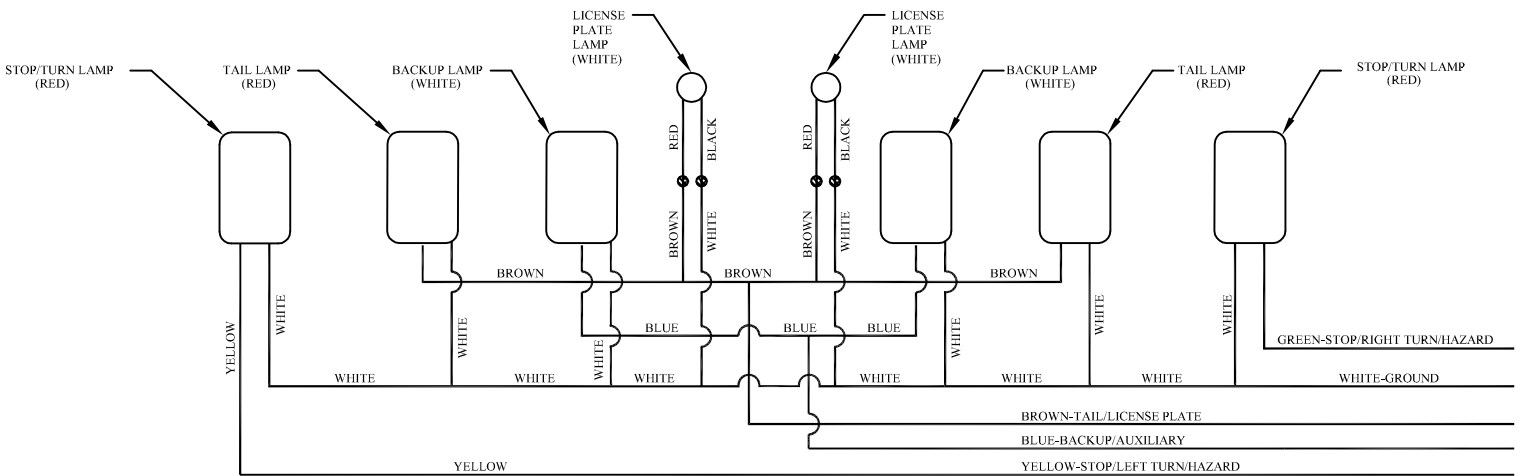

SEPARATED STOP/TURN FUNCTION

