

INSTALLATION GUIDE

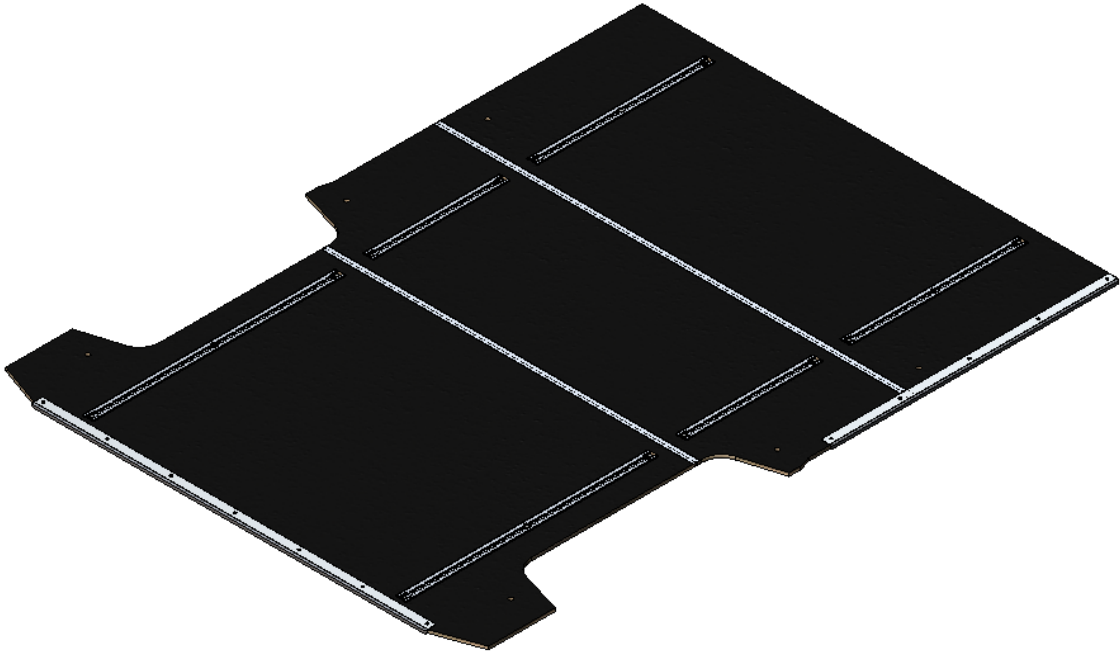

6540-PS FLOOR

Promaster (118" Wheelbase)



QUICK START GUIDE

Phase 1 - Assembly

- 1.1 Setup..... 3 - 4

Phase 2 - Installation

- 2.1 Install Preparation..... 5
- 2.2 Floor Installation..... 6 - 11

REQUIRED ITEMS

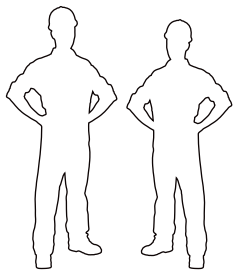

**2
PERSONS**

- Cordless Impact
- Tape Measure
- Rubber Mallet
- 7/16" Socket
- Plus Nut Tool
- T45 Torx Bit
- 3/8" Impact Bit
- Marker
- 3/8" Drill Bit
- Drill Collar (Set at 1/2")
- 1" Hole Saw

PHASE 1 – ASSEMBLY

1.1 SETUP

1.1.1 Unpack components; compare with the bill of materials.

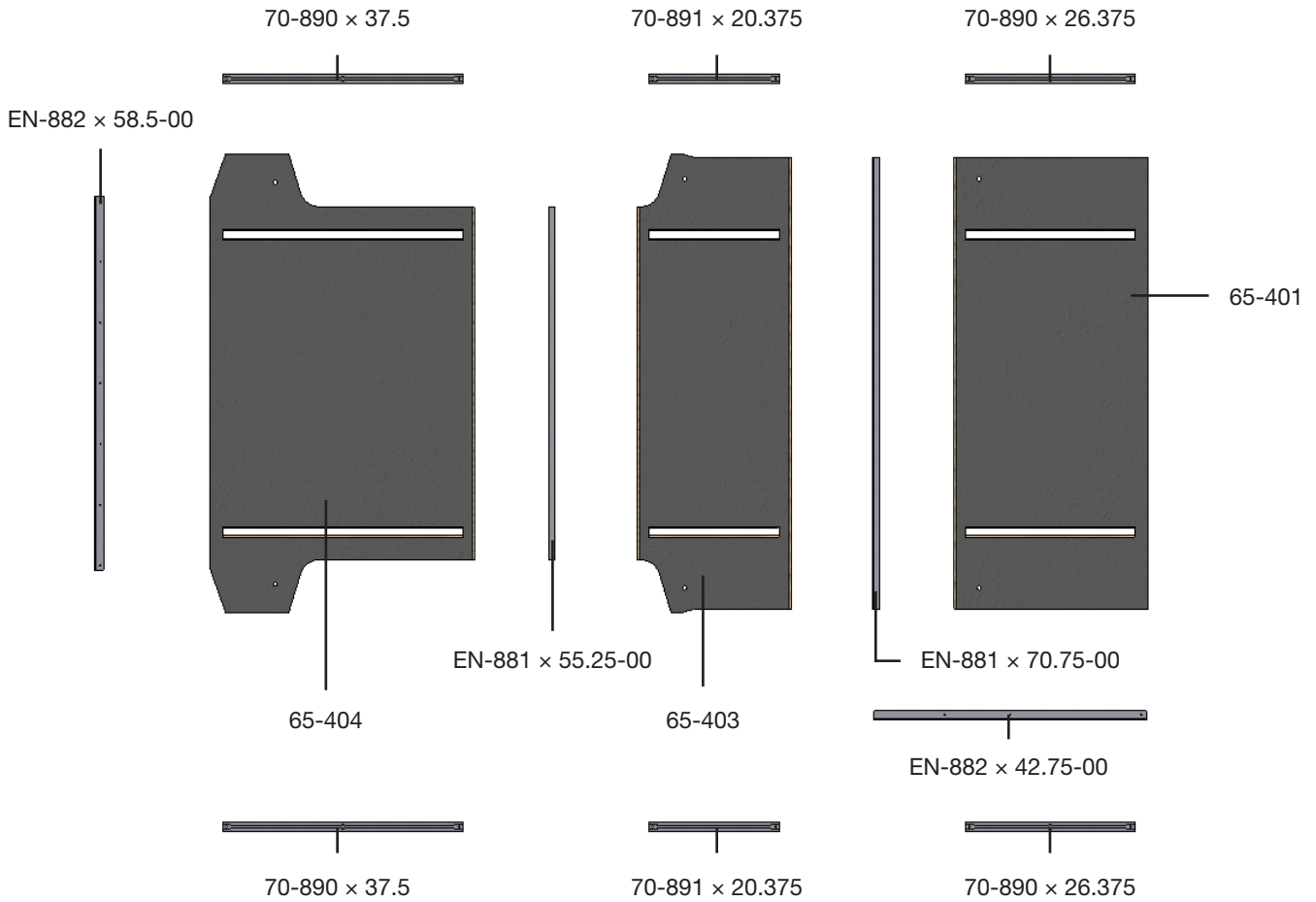

1.1.2 Verify all parts are present.

BILL OF MATERIALS

Item No.	Description	Qty.
65-401	Floor Panel (Front)	1
65-403	Floor Panel (Middle)	1
65-404	Floor Panel (Rear)	1
EN-882 x 58.5-00	Sill (Side)	1
EN-882 x 42.75-00	Sill (Rear)	1
70-890 x 26.375	Extrusion Machined (26 - 3/8")	2
70-890 x 37.5	Extrusion Machined (37 - 1/2")	2
70-891 x 20.375	Extrusion Machined (20 - 3/8")	2
EN-881 x 55.25-00	I Beam Extrusion (55 - 1/4")	1
EN-881 x 70.75-00	I Beam Extrusion (70 - 3/4")	1
96-6007	Install Fastener Kit	1

1.1.3 Fastener kits.



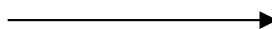

96-6007 Fastener Kit



Fastener Install

16x		# 90-114	Hex Bolt 1/4"-20 x 1" ZINC
6x		# 90-490	Bolt Carriage 5/16"-18 x 1" ZINC
6x		# 92-102	Screw #14 x 1" ZINC
12x		# 92-200	Screw #10 x 3/4" ZINC
6x		# 94-104	Hex Nut 5/16" - 18 ZINC
16x		# 94-130	Plus Nut 1/4" - 20
16x		# 98-112	Flat Washer 1/4", O.D. 3/4" ZINC
6x		# 98-116	Flat Washer 5/16", O.D. 7/8" ZINC
16x		# 98-118	Lock Washer 1/4" ZINC
6x		# 98-122	Lock Washer 5/16" ZINC
16x		# 98-157	Spacer 0.375" ID, 1" OD, 0.250" Thick Nylon





16x

 #90-114 Hex Bolt 1/4" x 1"
 #98-118 Lock Washer
 #98-112 Flat Washer
 #98-157 Spacer
 #94-130 Plus Nut

12x

 #92-200 Screw 3/4"

6x FOR SHELVING INSTALLATION

 #90-490 Carriage Bolt 5/16" x 1"
 #98-116 Lock Washer
 #98-122 Flat Washer
 #94-104 Hex Nut

6x FOR SHELVING INSTALLATION

 #92-102 Screw 1"

PHASE 2 – INSTALLATION

2.1 INSTALL PREPARATION

2.1.1 Remove all the D-rings on the floor, and keep for reattachment.

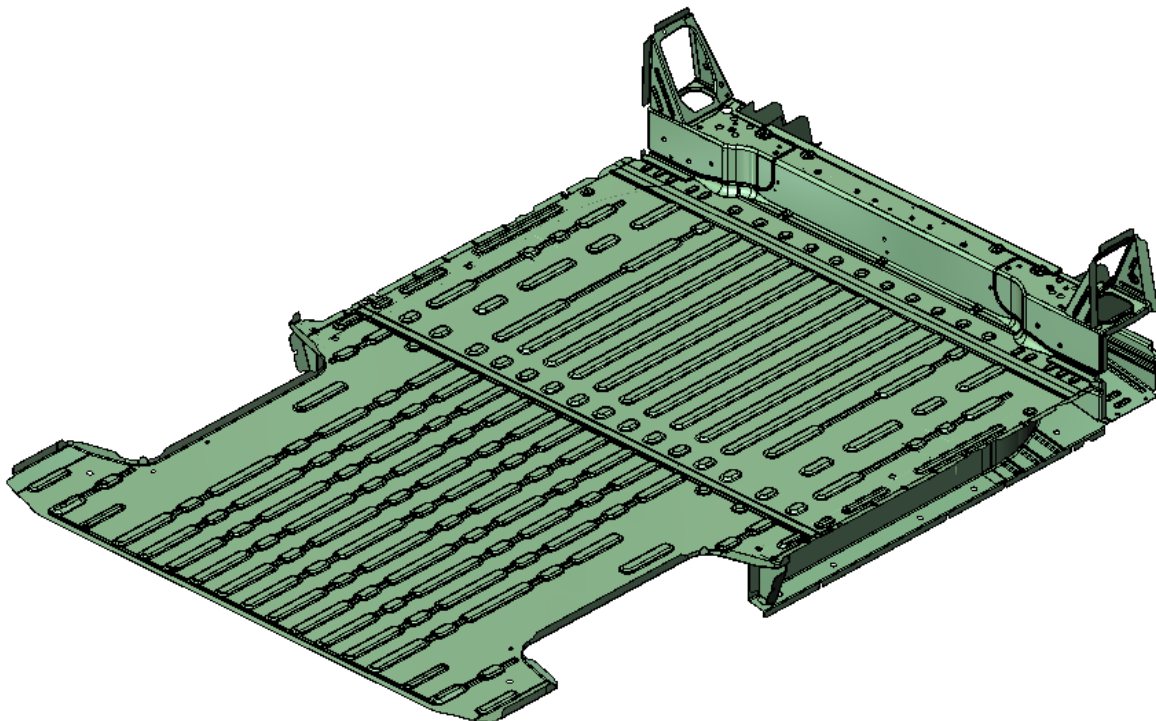

Remove all the D-rings, and keep for reattachment.

TOOLS

- Cordless Impact
- T45 Torx Bit

PHASE 2 – INSTALLATION

2.2 FLOOR INSTALLATION

2.2.1 Lift the three floor panels into the van, starting with the front panel, and attach together with the two EN-881 I beam extrusions.

NOTE: Make sure that the I beam extrusions are centered to the floor panels.

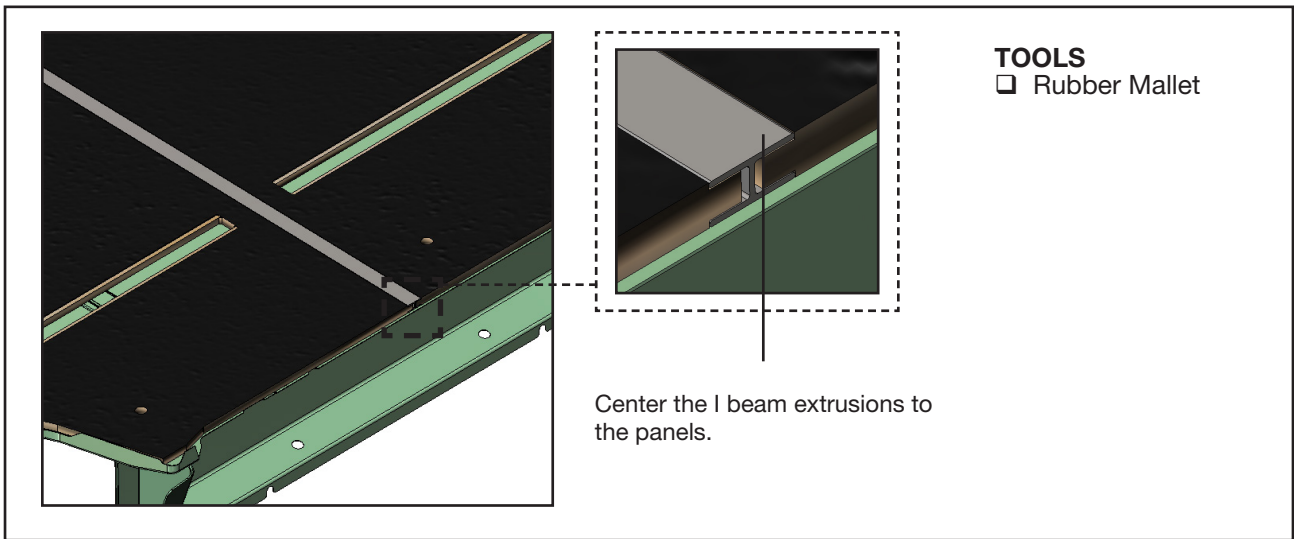
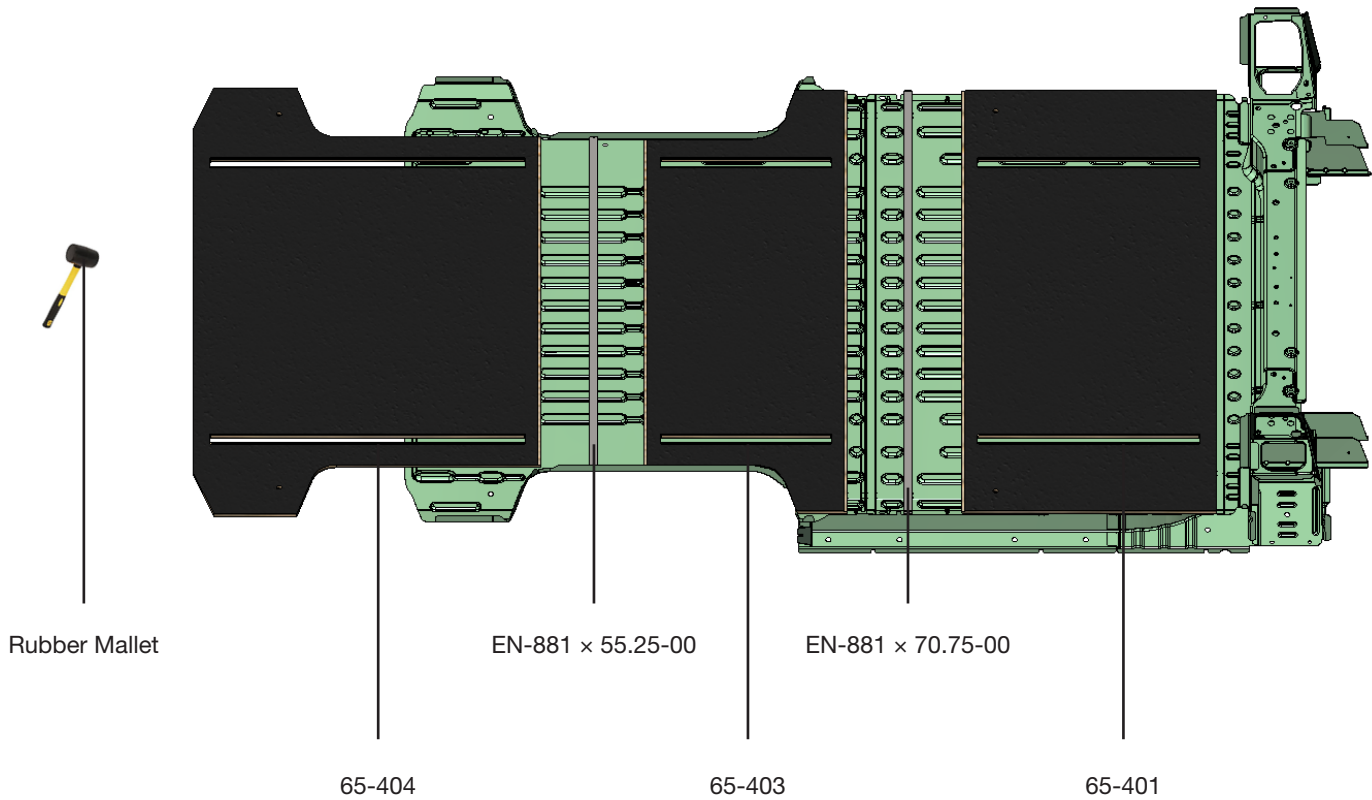

2.2.2 Screw the side sill to the floor panels.

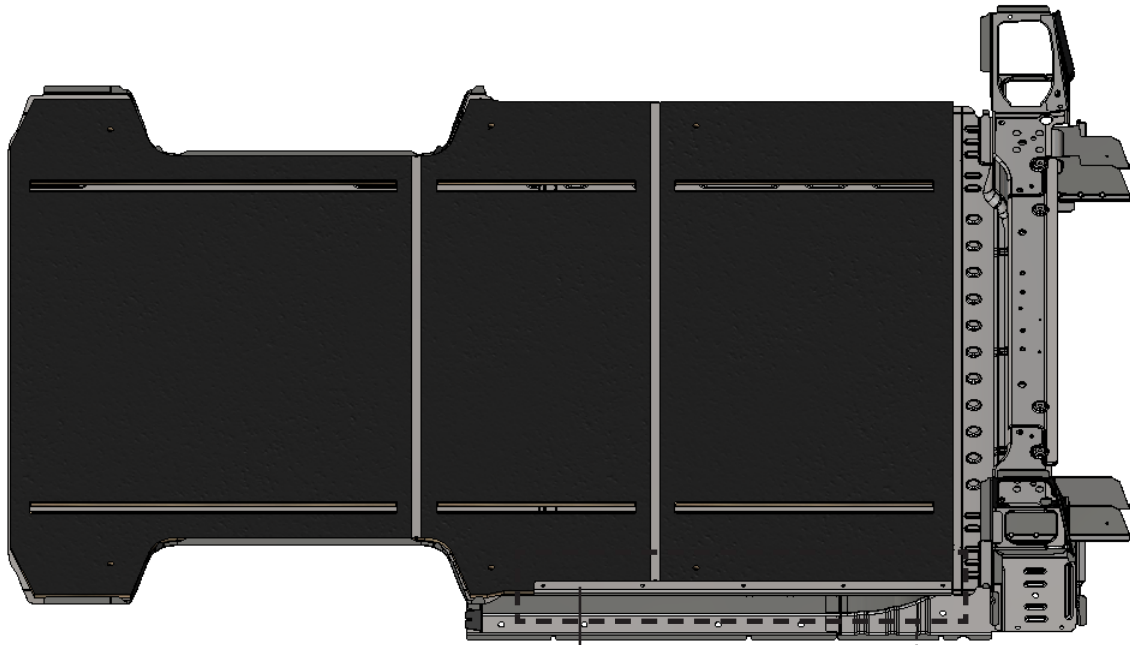

EN-882 x 42.75-00

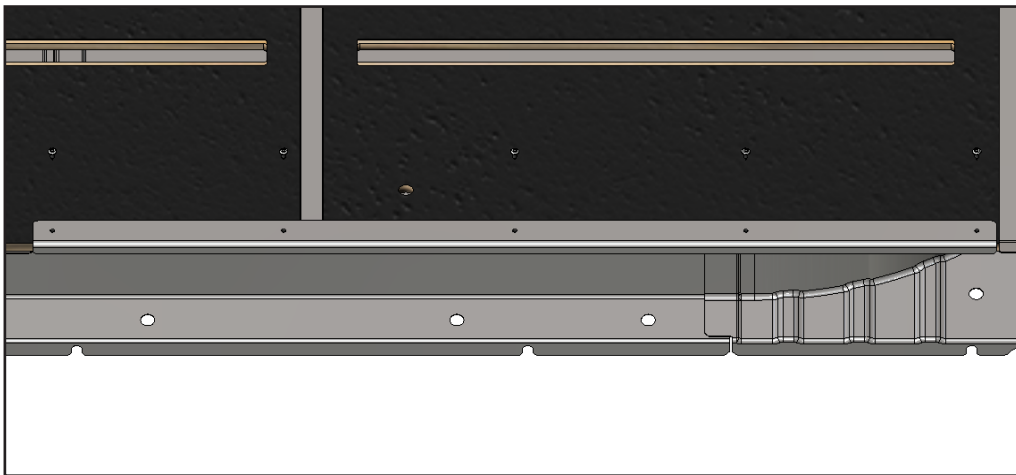

TOOLS

- Cordless Impact
- 3/8" Impact Bit

HARDWARE USED

5x



#92-200 Screw 3/4"

2.2.3 Screw the rear sill to the floor panel.

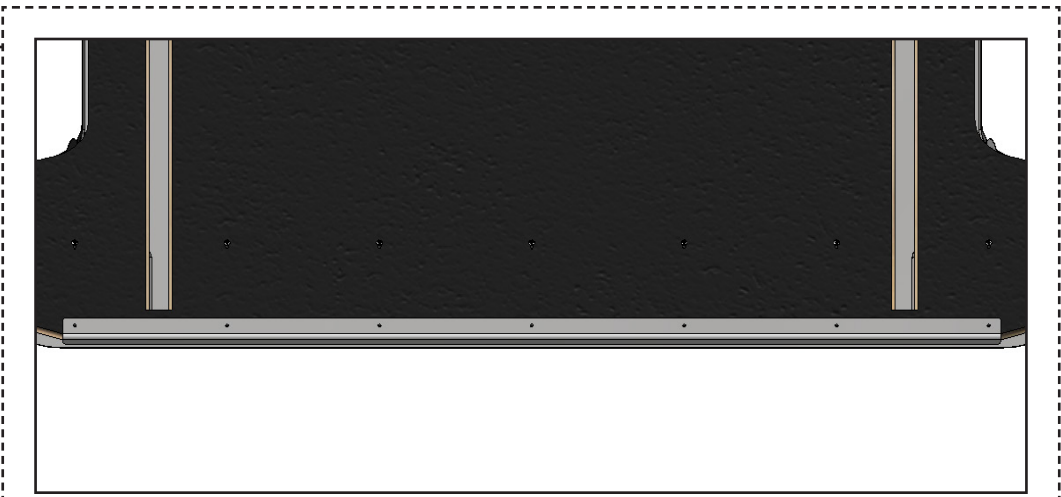
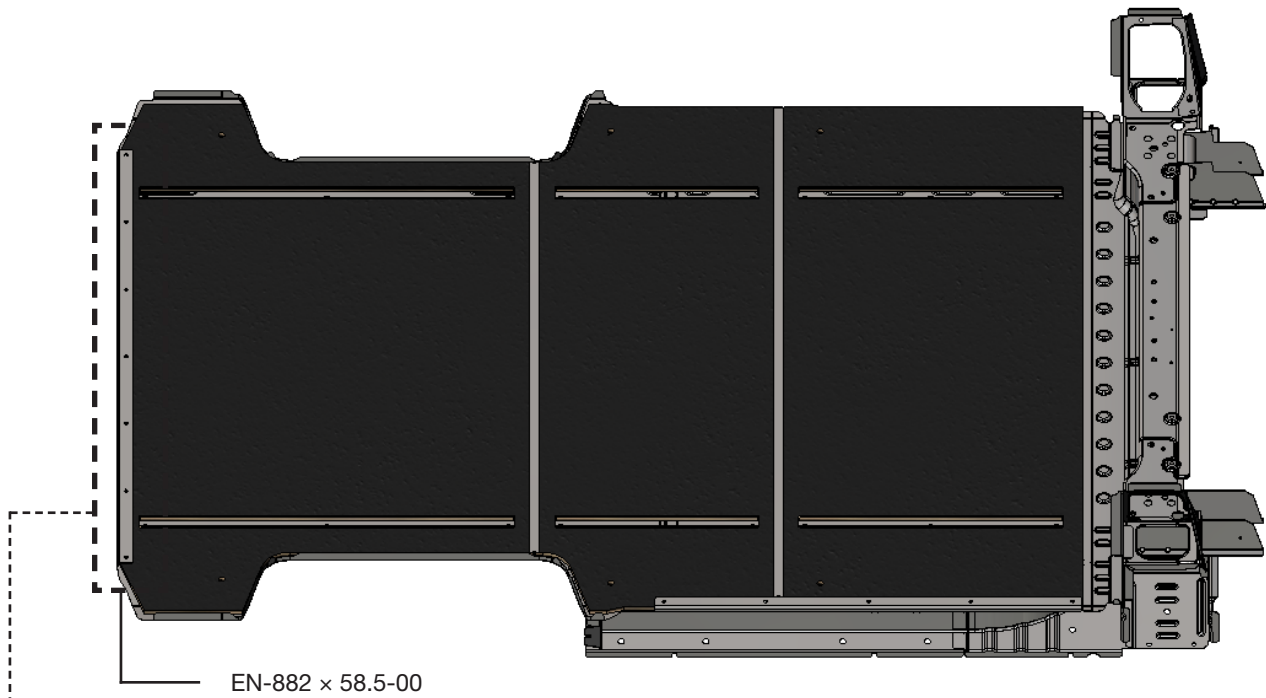

TOOLS

- Cordless Impact
- 3/8" Impact Bit

HARDWARE USED

7x



#92-200 Screw 3/4"

- 2.2.4** • Put the 37 - 1/2", 20 - 3/8" and 26 - 3/8" extrusions in place, then mark all the holes.
 • Remove the extrusions, then drill all the marks.

NOTE: Before drilling, ensure that you will not hit any critical parts of the vehicle like the **Gas tank**, **Wiring Harness** and **Hose**.

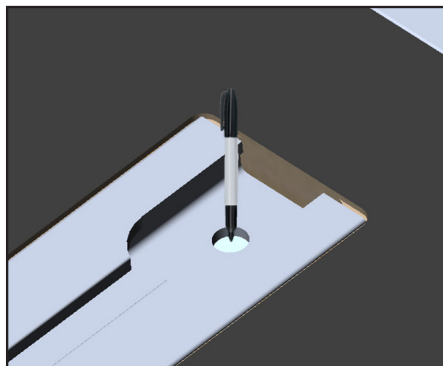
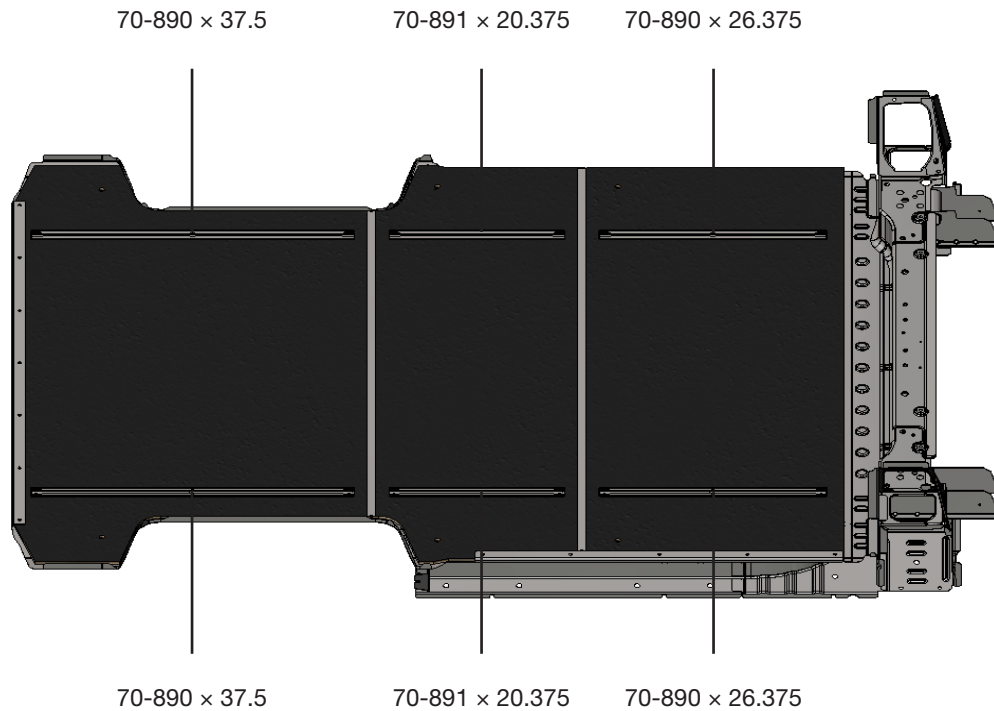

Mark all the holes

TOOLS

- Marker

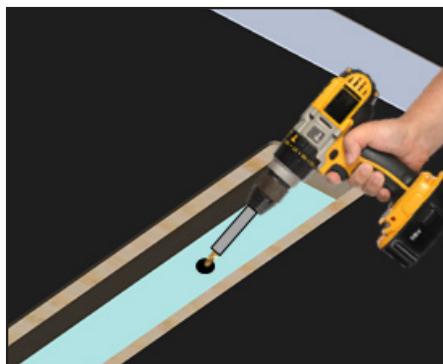

NOTE: If the mark is on the plastic cover, use 1" hole saw to drill the plastic cover, then use 3/8" drill bit with drill collar to drill the floor.

TOOLS

- Cordless Drill
- 3/8" Drill Bit
- Drill Collar (Set at 1/2")
- 1" Hole Saw

2.2.5 Attach plus nuts on the holes.

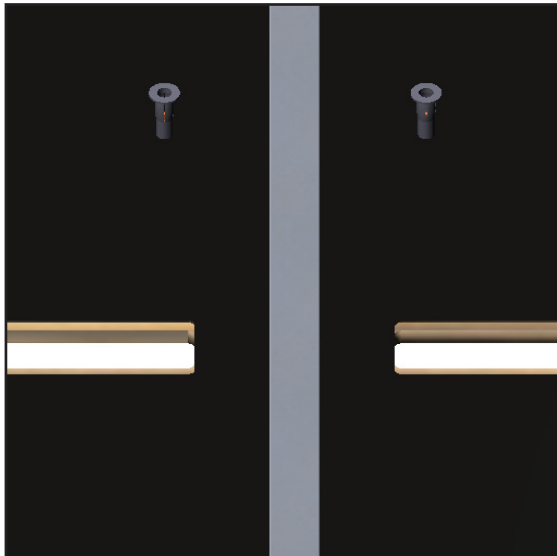
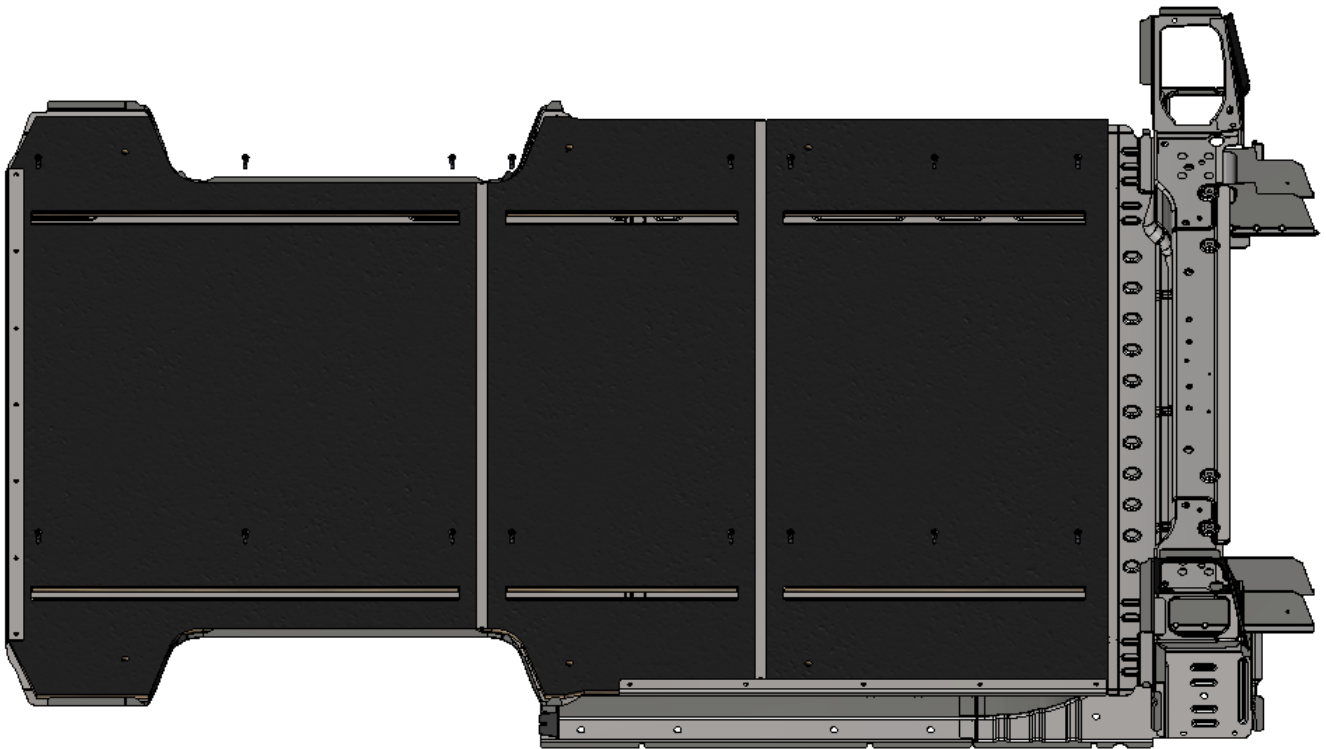

TOOLS

- ☐ Plus Nut Tool

HARDWARE USED

16x



#94-130 Plus Nut .250

2.2.6 Attach the 37 - 1/2", 20 - 3/8" and 26 - 3/8" extrusions.

NOTE: After attaching the extrusion reattach all the D-rings to the floor.

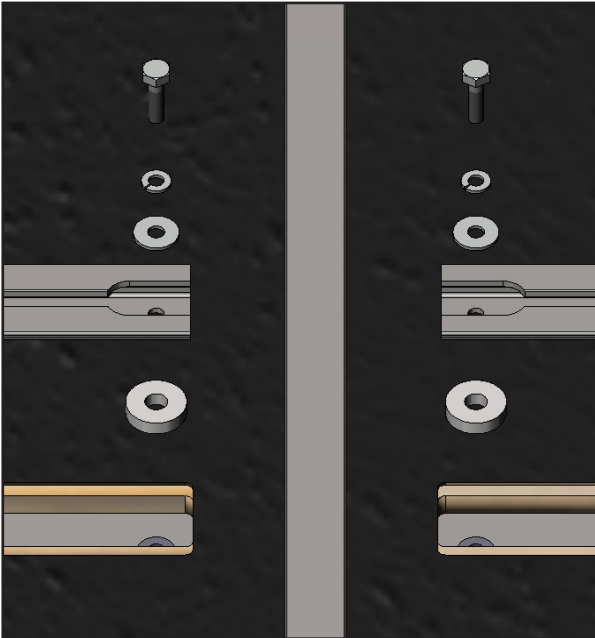
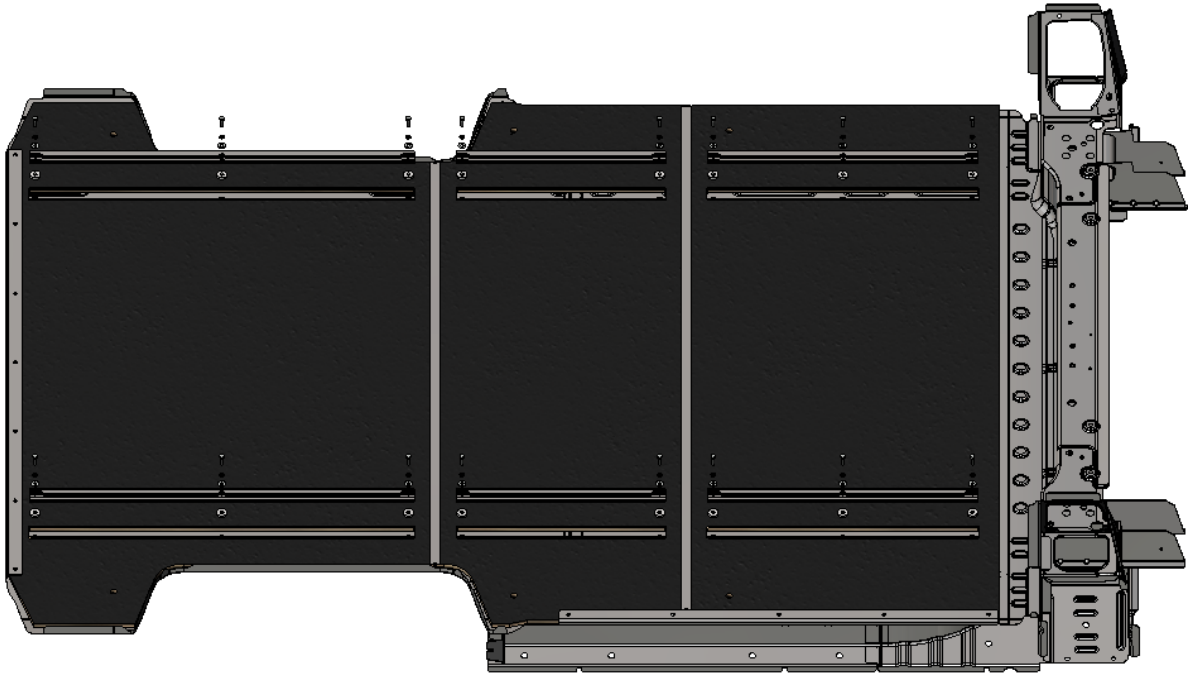

TOOLS

- Cordless Impact
- 7/16" Socket
- T45 Torx Bit

HARDWARE USED

16x

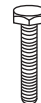

#90-114 Hex Bolt 1/4" x 1"



#98-118 Lock Washer



#98-112 Flat Washer



#98-157 Spacer



#94-130 Plus Nut (Already Installed)

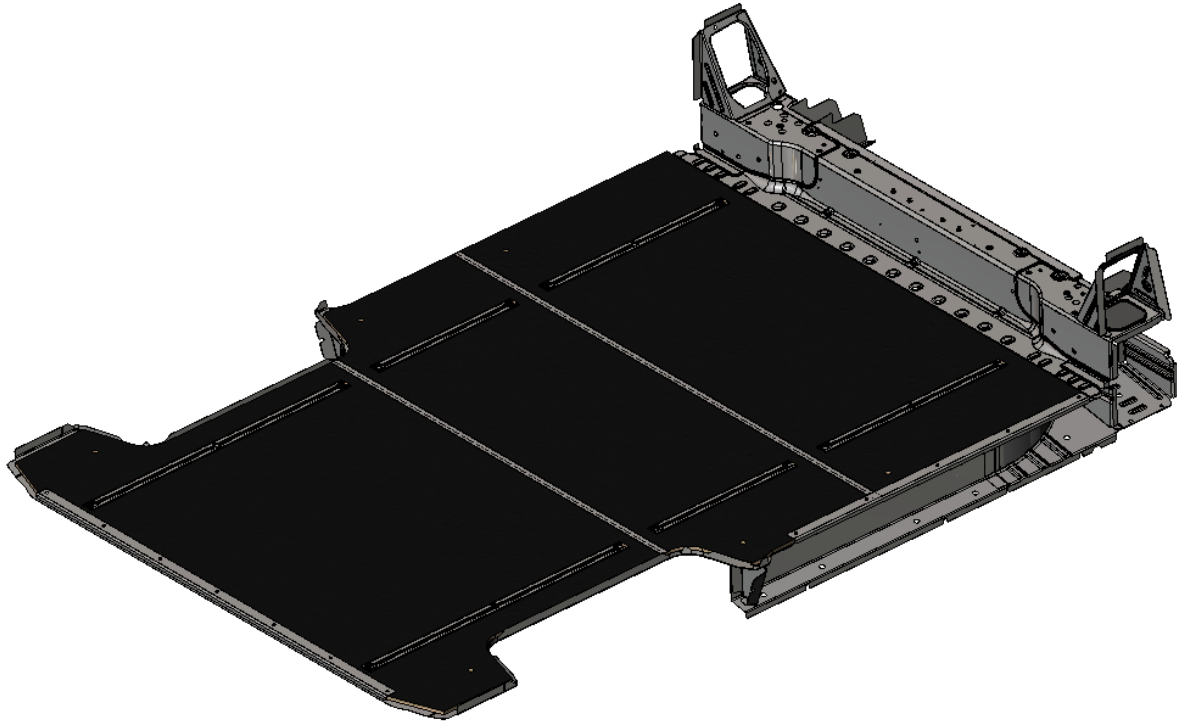

**“You have successfully installed your
Floor**

Thank you for doing business with us.”

For any feedback or suggestions you may have, please contact: cs@rangerdesign.com

