

# 650 Series Cargo Van Lift Mounting Instructions

Ford Transit (Standard Roof)  
2015-Present

# 13821

## Installing the Base Plate

- 1. Examine** the interior and exterior of the van for possible obstructions such as rear air conditioning, heater vents, electrical wiring, spare tire, etc (Figure 2).
- 2. Examine** the underside of the van for obstructions that could be damaged when drilling through the van floor: fuel tank, frame rail, spare tire, wiring, etc (Figure 2 and 3).
- 3. Verify** that the bed height of the van is not over 31-1/2".
- 4. Verify** that mounting bracket kit matches (Figure 1 and Table 1) and that this kit is for your van.

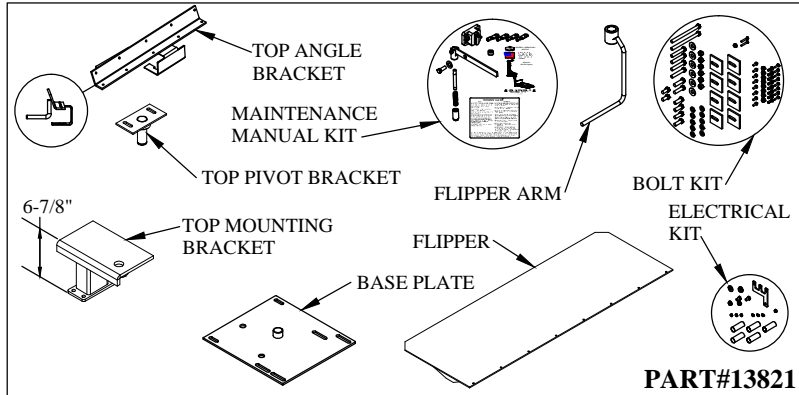

Figure 1: Part Identification.

Table 1: Parts List.

QTY.	PART NO.	DESCRIPTION
1	1094	650 Bolt Bag Kit
1	13820	Top Angle Bracket (Transit Standard Roof)
1	2424	Top Pivot Bracket (Ford)
1	2423	Top Mounting Bracket (Dodge)
1	1464	Flipper
1	1473	Flipper Arm (650-31)
1	1386	650 Base Plate
1	1062	Maintenance Manual Kit (650)
1	14122	Ford Transit Electrical Kit

- 5. Position** the base plate in the van as described in notes A or B (Figure 3). The base plate should be parallel with the floor ribs, not the van doors.

Note A: The base plate can be located by measuring 13-1/4" from the rear inside left wall of the van and 4-1/2" back from the closed door on the right side of the base plate.

Note B: The base plate can be located by measuring 9-1/2" from the rear inside left door opening of the van and 4-1/2" back from the closed door on the right side of the base plate.

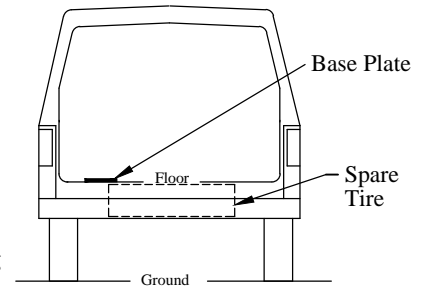

Figure 2: Base plate location and obstructions.

- 6. Position** the square washer plates under the base plate between the floor ribs, if needed. The area around the mounting holes must be properly supported by the metal floor.

- 7. Check** for obstructions before drilling in the next step.

- 8. Drill** holes through the floor for the base plate, using the base plate slots as a guide. Pay close attention to which slots in the base plate to use. The rear two bolts do not go all the way through the rear cross member.

- 9. Bolt** the base plate to the vehicle floor using the hardware provided. There are access holes in the bottom of the rear cross member for the rear two bolts (Figure 4).

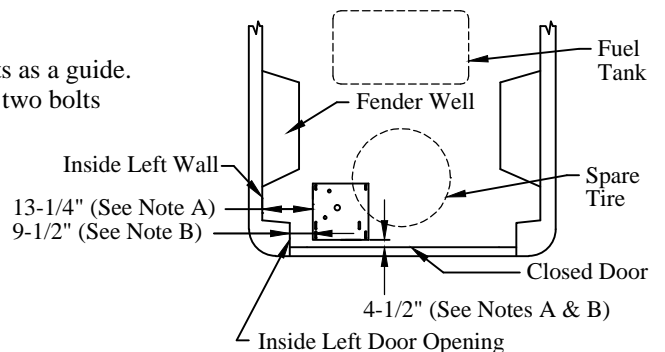

Figure 3: Base plate location and obstructions.

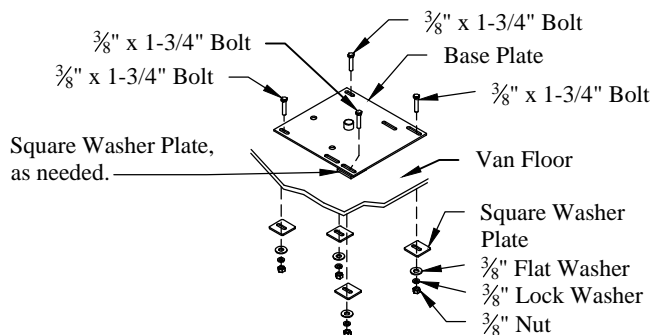

Figure 4: Base plate hardware.

**Installing the Top Mounting Brackets**

1. **Install** the swing release latch assembly (Figure 5). This must be done before mounting the liftgate.
2. **Remove** any plastic trim which is in the way of the upper support parts.
3. **Support** the lift to keep it from falling in the next steps.
4. **Attach** the top mounting bracket with the 3/8" x 1" bolts and lock washers (Figure 6).
5. **Attach** the top pivot bracket to the top angle bracket with the supplied 3/8" bolts, flat washers, lock washers, and nuts (Figure 7). Apply blue LockTite® Thread Locker or equal to the bolts before tightening.

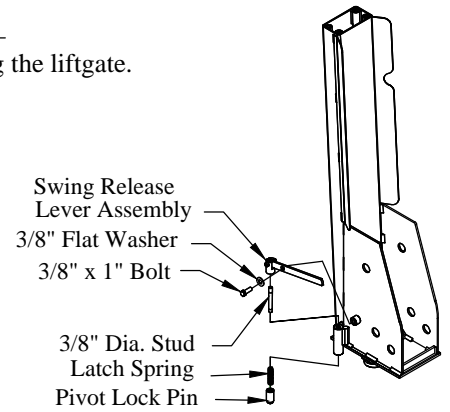

Figure 5: Swing release latch.

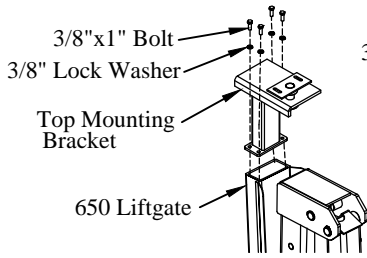

Figure 6: Top mounting bracket.

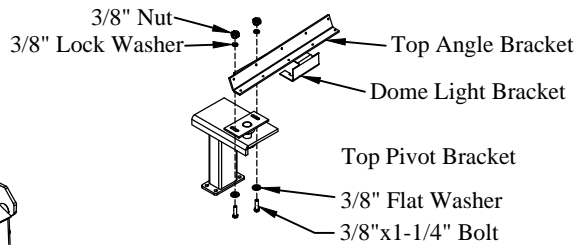

Figure 7: Top angle bracket.

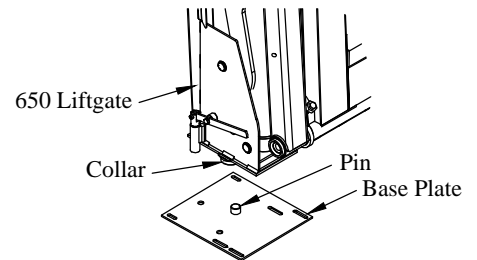

Figure 8: Base plate pin location.

**Mounting the Liftgate in the Van**

1. **Support** the liftgate securely to keep it from tipping while performing the next steps.
2. **Position** the liftgate collar onto the base plate pin (Figure 8).
3. **Position** the liftgate in the rear opening such that the top angle bracket comes in contact with the rear door header (Figure 9).
4. **Install** the vehicle dome light in the bracket provided on the top angle bracket.
5. **Position** the liftgate so it is tipped 3 degrees back and 1 degree to the left (Figure 10).
6. **Tighten** all hardware.
7. **Hold** the top angle bracket against the rear door header.
8. **Locate** and **Drill** eight (8) 5/16" holes into the rear door header, using the top angle bracket as a guide. Choose eight (8) of the angle bracket holes without obstructions.
9. **Assemble** the Plusnut with the 1/4" crown lock nut and 10-32 x 1-1/4" hex bolt (Figure 11)
10. **Insert** the Plusnut into the 5/16" drilled hole (Figure 12).
11. **Tighten** the hex bolt while holding the 1/4" nut (Figure 13). Fully upset Plusnut provides mounting nut to attach the top angle bracket (Figure 14).
12. **Attach** the top angle bracket to the header using the supplied 10-32 x 3/4" hex bolts. Apply blue LockTite® Thread Locker or equal to the bolts before tightening.

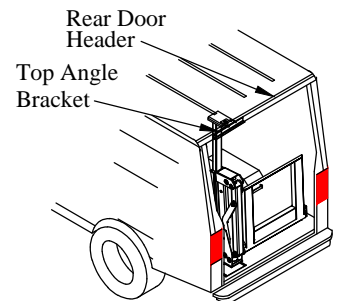

Figure 9: Liftgate in rear opening.

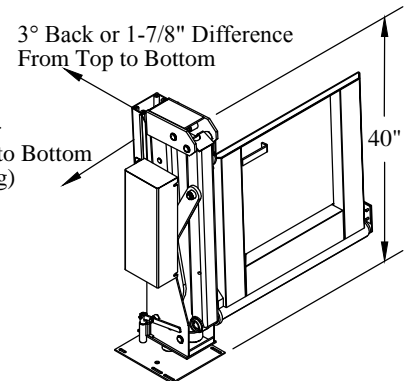

Figure 10: Liftgate properly tipped.

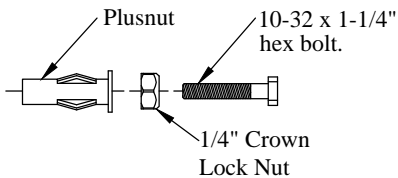

Figure 11: Plusnut Parts.

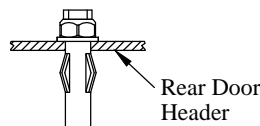

Figure 12: Assembled Plusnut.

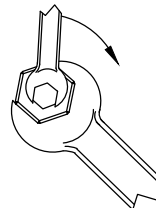

Figure 13: Plusnut tightening.

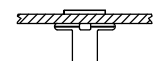

Figure 14: Fully upset Plusnut.

## Mounting the Liftgate in the Van (continued)

12. **Push** down on the swing release lever.  
This will unlock the release pin allowing you to rotate the complete liftgate.
13. **Verify** that the swing release pin will latch in both the stored and operational positions.
14. **Loosen** the four (4) pump box bolts (Figure 16).  
The bolts do not need to be removed.
15. **Remove** the pump box cover (Figure 16).
16. **Remove** the solid plastic shipping plug from the reservoir (Figure 16).
17. **Install** the the vent plug. Failure to change the plug will damage the reservoir.

Note: The hydraulic system has been filled with the proper amount of oil, do not add any at this time.

Note: Pump and motor unit must remain vertical during operation, or it will be damaged.

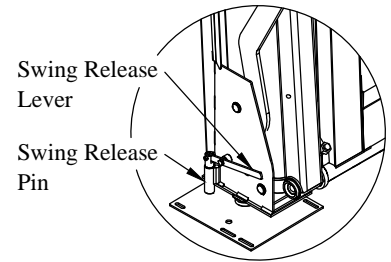

Figure 15: Swing release feature.

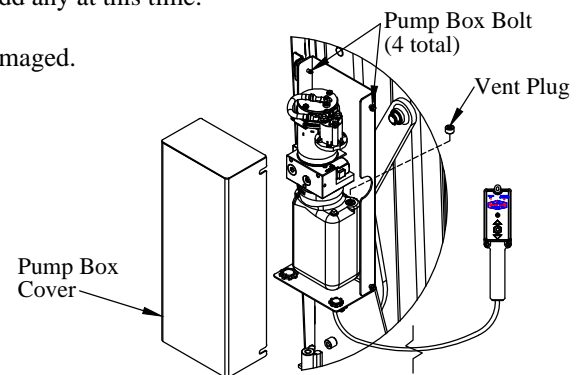

Figure 16: Pump and motor unit.

## Routing the Power Cables

Note: Ford recommends using the vehicle Customer Connection Points (CCP) to power the liftgate. Vehicle option 67C-User Defined Upfitter Switches, provides three (3) 60 amp CCP, which can be combined into one 180 amp connection. If three (3) CCP are not available, large loads can be connected to an empty M6 stud on the positive battery terminal using the supplied M6 lock nut (Ford Bulletin Q-226R1). If neither of these options are available, Ford part number BK2Z-14S411-A adds the additional CCP.

1. **Install** the circuit breaker on the floor behind the driver seat, near the battery, leaving enough room for the power cables to be installed and so that the circuit breaker can easily be reset.
2. **Remove** the plastic cover from the Customer Connection Points (CCP) on the driver seat pedestal (only if using the CCP for power, Figure 17).

Note: Any time a hole is drilled in the vehicle, apply rust preventative to the bare metal.

3. **Check** for obstructions before drilling in the next step.
4. **Drill** and **Deburr** a hole in the van floor, near the power unit, to run the power cables through.  
Use a rubber grommet to protect the power cables from the sharp sheet metal edge of the drilled hole.
5. **Drill** and **Deburr** a 5/8" hole in the floor next to the driver seat in the location shown (Figure 17).  
An alternate location will be needed if there is a trailer brake controller in the way.
6. **Install** the supplied bus bar on the CCP studs using three (3) supplied M5 nuts and star washers (only if using the CCP for power, Figure 17). The bus bar combines three (3) 60 amp connections into one 180 amp connection point.

Note: Follow the *Tommy Gate Recommended Electrical Wiring Guidelines* and wiring diagram (Figure 18) in the following steps.

7. **Route** the power cables under the vehicle from the liftgate, along the driver side frame, to a location under the driver door (Fig. 17).  
Leave enough extra power cable between the liftgate and the drilled hole for the liftgate to pivot into the stored position.
8. **Separate** the positive(+) and negative(-) leads.
9. **Pull** the positive(+) lead through the drilled 5/8" hole in the floor, using the supplied grommet.
10. **Cut** the positive(+) lead to the length required to reach the auxiliary (AUX) terminal of the circuit breaker.
11. **Cut** the remaining positive(+) lead long enough to reach from the circuit breaker battery (BAT) terminal to the bus bar connection on the driver seat pedestal (Figure 17) or the positive(+) battery terminal.
12. **Cut** the negative(-) lead to the length required to reach a vehicle ground point under the vehicle (Figure 17).

**IMPORTANT:** The pump and motor unit for this lift can require up to 110 amps of electrical power at 12 volts D.C.  
Be sure that the negative(-) ground lead is securely connected to a sufficient vehicle ground point.

13. **Install** the copper lugs on all required ends. If connecting to an empty M6 stud on the positive(+) battery terminal, be sure the copper lug fits completely flush to the terminal.
14. **Connect** the negative(-) lead to a vehicle ground point under the vehicle using the supplied 5/16" x 1/2" bolt, lock nut, and heat shrink tubing (Figure 17).
15. **Connect** the circuit breaker (Figure 18). Use the supplied heat shrink tubing.
16. **Complete** Step 17 only if connecting to the positive battery terminal or  
**Complete** Steps 18 and 19 only if using the CCP bus bar.

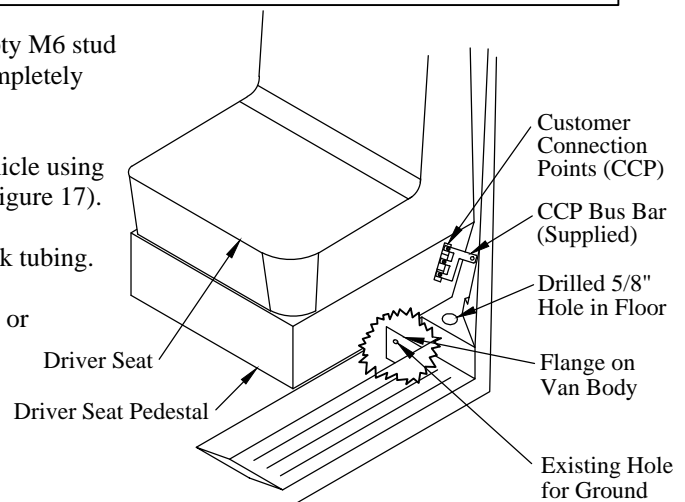

Figure 17: Customer Connection Point location.

Routing the Power Cables (continued)

17. **Connect** the positive(+) lead to an empty M6 stud on the positive battery terminal (Ford Bulletin Q-226R1). Use the supplied M6 lock nut. Do not connect to the stud occupied by the alternator sensing circuit.
18. **Connect** the positive(+) lead to the CCP bus bar. Use the supplied 5/16" x 1/2" bolt, lock nut, and two (2) pieces of heat shrink tubing to cover the cable connection to the bus bar.
19. **Install** the plastic CCP cover on the bus bar cable connection (if previously removed). The cover will need to be trimmed for bus bar clearance.
19. **Pull** the excess cable into the pump box.
20. **Tighten** the two-screw strain relief.
21. **Push** the hidden "Power On" switch (Figure 18). The amber "Power On" LED will illuminate.
22. **Push** the hidden "Liftgate Activated" switch twice within one second. The red "Liftgate Activated" LED will illuminate.

Note: With both lights on, the liftgate can be raised or lowered. If not used for 90 seconds, the control will automatically shut off.

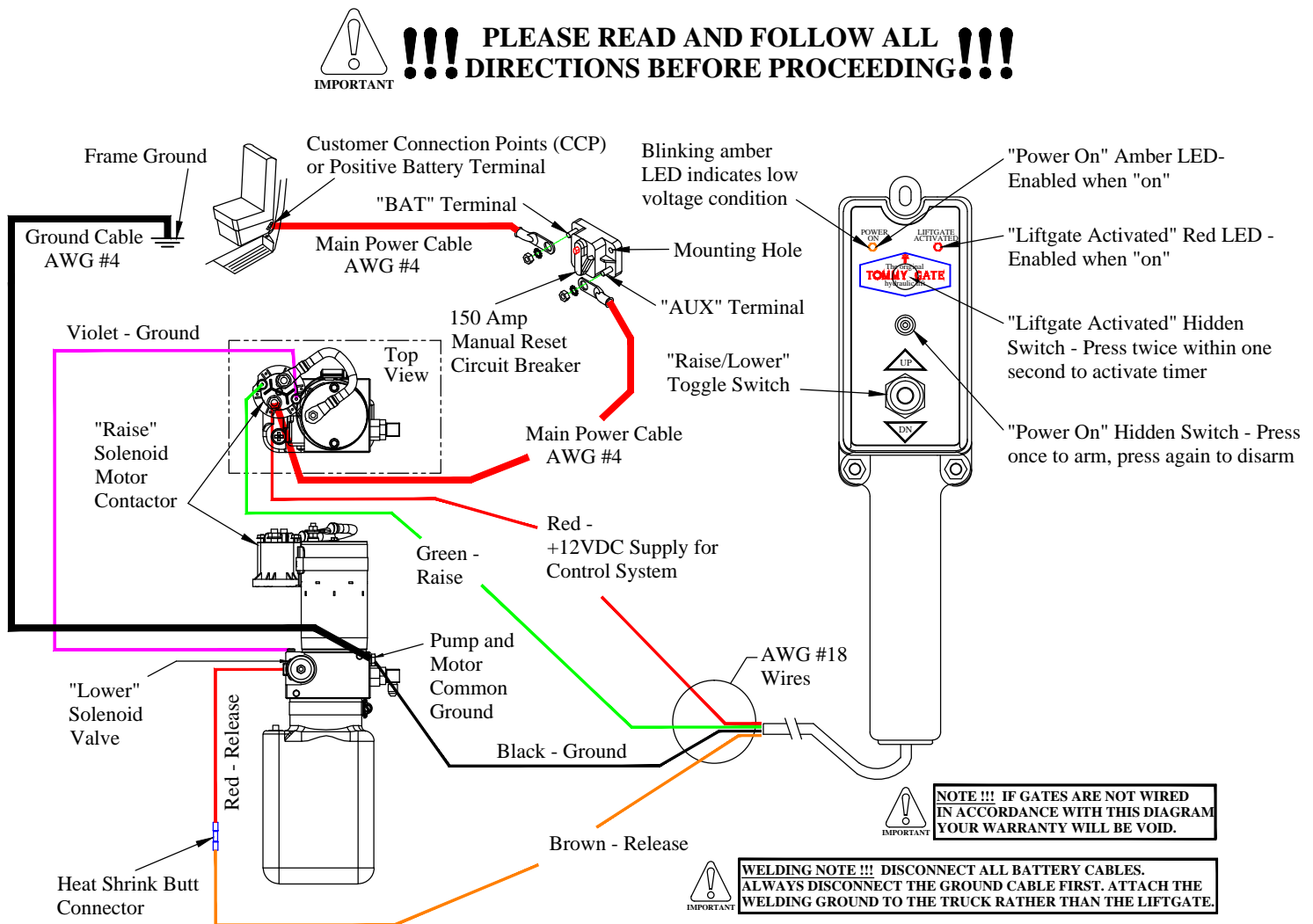

Figure 18: Wiring Diagram.

**Installing the Flipper Kit**

1. **Verify** proper liftgate operation.
2. **Loosen** the jam nut (Figure 19).
3. **Completely** tighten the adjustment bolt.
4. **Lower** the gate until it contacts the ground.  
The taper edge of the platform may not contact the ground at this point.
5. **Loosen** the adjustment bolt until the taper edge of the platform contacts the ground.
6. **Tighten** the jam nut
7. **Remove** the 3/8" x 1-1/4" bolt weldment that holds the self-closing arm to the platform (Figure 20).
8. **Remove** the rod from the tube (Figure 21).
9. **Install** the flipper arm over the self-closing tube (Figure 22).
10. **Tighten** the 1/4" set screw on the flipper arm (Figure 22).
11. **Reinstall** the self-closing rod and 3/8" x 1-1/4" bolt weldment (Figure 23).
12. **Attach** the flipper to the hinge on the platform using eight (8) 8-32x1/2" screws and 8-32 nylon lock nuts (Figure 24).
13. **Raise** the platform to bed height.
14. **Loosen** the set screw on the flipper arm.
15. **Adjust** the flipper arm up or down until it just touches the bottom of the flipper when the flipper rests on the van floor.
16. **Tighten** the set screw.
17. **Verify** that the flipper has no obstructions and clears the bumper when raising and lowering the liftgate.

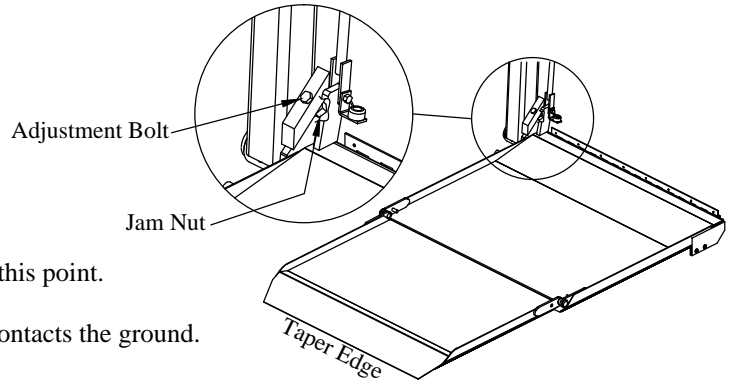

Figure 19: Unfolded 650 platform.

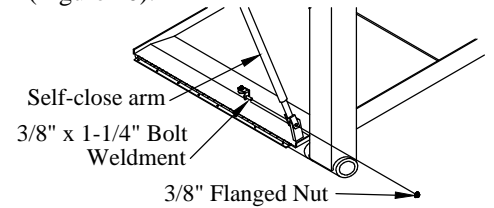

Figure 20: Self-close arm parts.

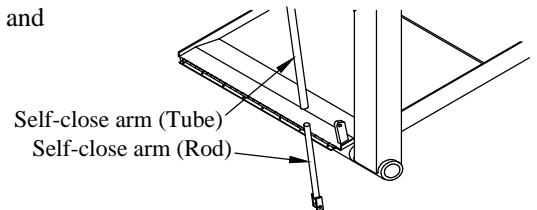

Figure 21: Self-close arm parts.

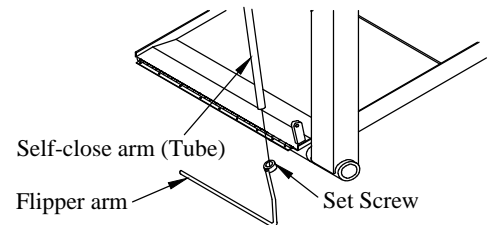

Figure 22: Flipper arm location.

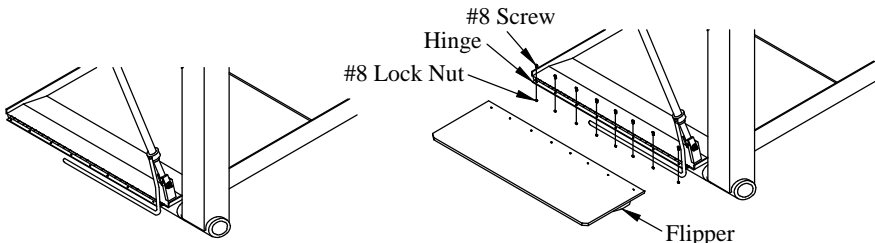

Figure 23: Flipper arm assembled.

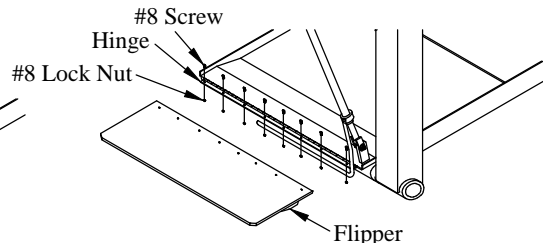

Figure 24: Flipper hinge hardware.

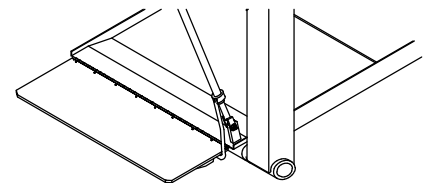

Figure 25: Flipper installed.

**Finishing the Installation**

1. **Test** the liftgate unloaded and at rated capacity for proper operation.
2. **Demonstrate** the proper operation to the operator.
3. **Provide** the owner/operator's manual and "Do's and Do Not's" decal to the operator, or place them in the vehicle.

## WIRE ROUTING

- (1) When routing wires, avoid heat (above 180°F), abrasion, vibration, metal edges, screws, and trim fasteners. If such routings are not possible, protective devices must be used. If wires must cross a metal edge, the edge should be covered with a protective shield and the wiring fastened within 3 inches on each side of the edge.
- (2) Grommets must be used where wires pass through holes in sheet metal, castings, and / or frame rails. Do not bend wires in a radius smaller than 10 times the wire diameter.
- (3) Routing wires into areas exposed to wheel wash should be avoided. If this cannot be avoided protective shields are required to protect the wires from stones, ice, salt and water damage. Provide a drip loop to prevent moisture from being conducted into switches, relays, circuit breakers, and fuses.
- (4) Wires should be supported every 18 inches with plastic zip ties or rubber-lined clips.
- (5) Wires must be routed to clear moving parts by at least 3 inches unless positively fastened or protected by a conduit. If wiring must be routed between two members where relative motion can occur, the wiring should be secured to each member, with enough wire slack to allow flexing without damage to the wire.
- (6) Maintain at least a 6 inch clearance from exhaust system components. If this is not possible, high temperature insulation and heat shields are required. Existing OEM heat shields, insulation, and wire shielding must be maintained.
- (7) Do not route or attach electrical wires to fuel lines. Route electrical wires at least 1-1/2 inches away from the engine.

## BATTERY, WIRE, TERMINALS, AND CONNECTORS

- (1) Wire attachments at the battery must be protected from tension loads so there is no undue strain on the battery terminals. Wires should be routed down rather than horizontally from the terminals with no sharp bends adjacent to the connections.
- (2) Battery power for your Tommy Gate should come directly from the battery or approved connection point through the supplied circuit breaker or fuse. The circuit breaker or fuse should be installed as close to the battery as possible.
- (3) Avoid splicing power cables. If splicing is necessary, the most durable splice joint will be bare metal barrel crimped, flow-soldered and covered with adhesive lined heat shrink tubing. Strip the wire ends making sure that individual conductor strands are not damaged. Use only rosin core solder, proper crimping tools, and wire with a gauge at least equivalent to the circuit being lengthened. Do not use electrical tape.
- (4) Battery cable terminals will be bare metal barrel crimped or flow-soldered and covered with adhesive lined heat shrink tubing.
- (5) Use wire connectors with locking features such as positive locking, inertia locking, bolt together, and soft mold-over with locking external retainers.

## GENERAL

- (1) All frame contact areas must be wire brushed to bare metal, free of paint, dirt, and grease. Frame connections must be made using hardened flat washers under the bolt head and lock nuts. Corrosion preventive grease or compound is to be applied to the terminal area of the frame connection.
- (2) Frame cross members are not recommended as part of the ground return.
- (3) All circuit breakers and fuses should be located in one easily serviceable location with a means provided for identification of circuit function and current rating. If possible, avoid putting circuit breakers or fuses in the vehicle cab.
- (4) Before welding to the chassis disconnect the battery. Also disconnect the power train, engine, valve, and transmission control modules.
- (5) Do not alter vehicle ignition, starting, and / or charging systems. Do not reroute engine compartment wiring.
- (6) Full copper circuitry and standardized polarity grounds are recommended.
- (7) Never increase the rating of a factory installed fuse or circuit breaker.
- (8) Disconnect the battery negative (ground) wire prior to any vehicle modification.

Following the above guidelines will provide you with years of trouble free service. Failing to incorporate the above guidelines may result in a voided warranty. Non-compliance with the guidelines above may result in a failure of electrical components, shutdown of engines, loss of backup brake systems, and the possibility of fire.